

HITROL CO., LTD.

HEAD OFFICE.FACTORY.R&D INSTITUTE
HITROL CO., LTD. 141, Palhakgol-gil, Jori-eup
Paju-si, Gyeonggi-do, Korea
TEL. : (00)-82-31-950-9700
FAX. : (00)-82-31-943-5600
www.hitrol.com



INSTRUCTION MANUAL

FLOAT TYPE LEVEL SWITCH

HR-30 Series



Doc. no.: HR30_IM_Eng_Rev.10.4

Issue date: 2024. 08

Table of Contents

Overview	3	Maintenance	13
Operation Principle	3	Precautions for Removal	13
Characteristics	3	Precautions for Installation	13
Specifications	4	Precautions for Inserted External Wire	13
Stainless Steel (Flange).....	4	Precautions for Grounding	14
Stainless Steel (Screw).....	4	Precautions for Attachment	14
PVC	5	Wiring	15
TEFLON	5	Matters regarding Operation and Use	15
Specifications Applied to the Float	5	Safety and Environment	16
Contact Point Capacity	6	Marking	16
SPST.....	6	User Training	17
SPDT	6	Warranty and Contact	17
Latching Switch.....	6		
Contact Form	6		
Minimum Section Distance	7		
Stainless Steel	7		
PVC	7		
TEFLON	7		
Float Application Table	8		
Product Composition	9		
Dimensions	10		
Weather-proof.....	10		
Ex-proof.....	10		
FLAP TYPE LEVEL GAUGE with HR-30 Series.....	10		



WARNING

You should be well-informed of the contents where WARNING is marked before carrying out the work.



CAUTION

You should be careful where CAUTION is marked to carry out the work.



NOTICE

You should be aware of where NOTICE is marked to carry out the work.

Overview HR-30 Series is a Float Type Level Switch which is basically operated with the usage of reed switch and magnet. It can be applied to various storage containers, including those in chemical factories, which are highly oxidative and corrosive. Also, it can be widely used in general industries with high reliability and long life spans.

Operation Principle As liquid level is changed in the tank, the float which is manufactured in accordance with the specific gravity of liquid moves upward or downward along the guide pipe with the same liquid level by buoyancy. The built-in magnet in the float activates reed switch which is located in the guide pipe and contact signal is out. Each alarm or H/L control with multiple setting points is available.

- Characteristics**
- Widely used to measure various liquid
 - Applicable to corrosive and acidic liquids with anti-corrosive material for the sensor (PVC, Teflon)
 - Applicable to explosion area (Ex-proof Version)
 - Long life cycle
 - Strong structure and high reliability

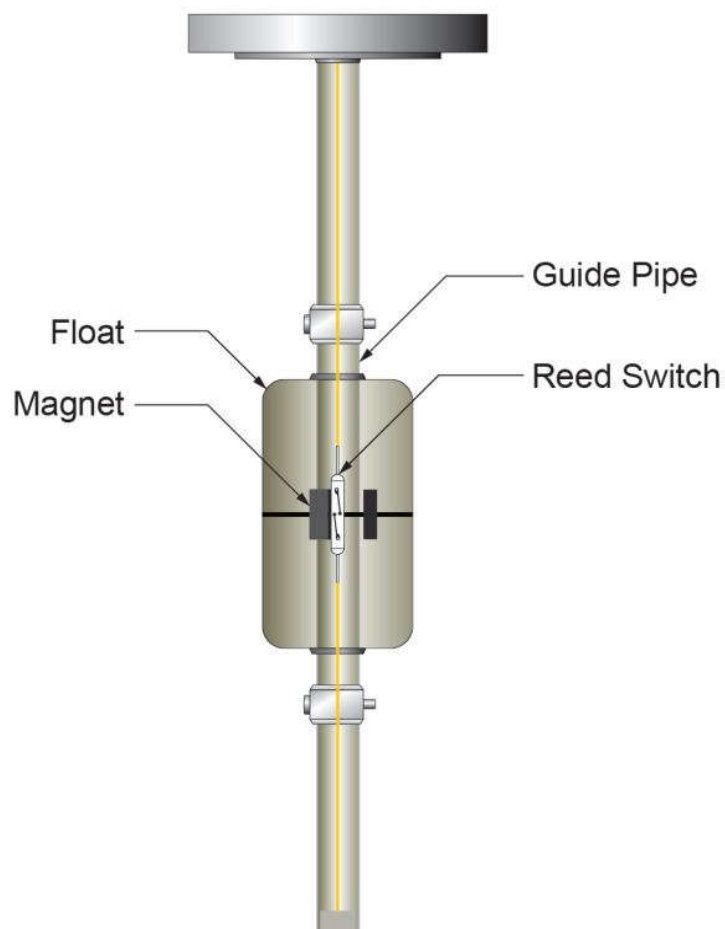

Product images are for reference only.

Specifications**Stainless Steel (Direct Mounting)**

Model	HR-30	HR-30H	HR-30-Ex	HR-30H-Ex
Mounting	Level Gauge(HLG-100F) Outside			
Temperature	Max. 120°C	Max. 150°C	T6 (Max. 70°C) T5 (Max. 80°C)	T4 (Max. 130°C) T3 (Max. 150°C)
Switch Type	Reed switch			
Contact Form	SPST, SPDT			
Enclosure	Weather-proof		Ex-proof(Ex d IIC T6/T5)	Ex-proof(Ex d IIC T4/T3)
Wetted Part Material	SUS316L			
Housing ; Cable Entry	ABS ; PF 3/4"(F), IP65	AL. ; PF 3/4"(F), IP65	AL. ; PF 1/2"(F), IP66	
Combination Unit	HLC-200A, HLC-300N, or HLC-400			

Stainless Steel (Flange Mounting)

Model	HR-30S	HR-30SH	HR-30S-Ex	HR-30SH-Ex
Mounting	Flange			
Temperature	Max. 80°C	Max. 150°C	T6 (Max. 70°C) T5 (Max. 80°C)	T4 (Max. 130°C) T3 (Max. 150°C)
Process Pressure	Up to 20kg/cm ² (300#)			
Switch Type	Reed switch			
Contact Form	SPST, SPDT			
Enclosure	Weather-proof		Ex-proof(Ex d IIC T6/T5)	Ex-proof(Ex d IIC T4/T3)
Wetted Part Material	SUS316L			
Process Connection	80A JIS 10K			
Housing ; Cable Entry	ABS ; PF 3/4"(F), IP65	AL. ; PF 3/4"(F), IP65	AL. ; PF 1/2"(F), IP66	
Combination Unit	HLC-200A, HLC-300N, or HLC-400			

Stainless Steel (Screw Mounting)

Model	HR-30C	HR-30CH	HR-30C-Ex	HR-30CH-Ex
Mounting	Screw			
Temperature	Max. 80°C	Max. 150°C	T6 (Max. 70°C) T5 (Max. 80°C)	T4 (Max. 130°C) T3 (Max. 150°C)
Process Pressure	Up to 20kg/cm ² (300#)			
Switch Type	Reed switch			
Contact Form	SPST, SPDT			
Enclosure	Weather-proof		Ex-proof(Ex d IIC T6/T5)	Ex-proof(Ex d IIC T4/T3)
Wetted Part Material	SUS316L			
Process Connection	PT 2"(M)			
Housing ; Cable Entry	ABS ; PF 3/4"(F), IP65	AL. ; PF 3/4"(F), IP65	AL. ; PF 1/2"(F), IP66	
Combination Unit	HLC-200A, HLC-300N, or HLC-400			

PVC

Model	HR-30V	HR-30V-Ex
Mounting	Flange	
Temperature	Max. 60°C	
Process pressure	Up to 0.5kg/cm ²	
Switch type	Reed switch	
Contact form	SPST, SPDT	
Enclosure	Weather-proof	Ex-proof (Ex d IIC T6)
Wetted part material	PVC	
Process connection	80A JIS 10K	
Housing ; Cable entry	ABS ; PF 3/4"(F), IP65	AL. ; PF 1/2"(F), IP66
Combination unit	HLC-200A, HLC-300N, or HLC-400	

TEFLON

Model	HR-30T	HR-30TH	HR-30T-Ex	HR-30TH-Ex
Mounting	Flange			
Temperature	Max. 80°C	Max. 150°C	Max. 80°C	Max. 150°C
Process pressure	Up to 0.5~3kg/cm ²			
Switch type	Reed switch			
Contact form	SPST, SPDT			
Enclosure	Weather-proof		Ex-proof (Ex d IIC T6)	
Wetted part material	SUS316L + TEFLON			
Process connection	80A JIS 10K			
Housing ; Cable entry	ABS ; PF 3/4"(F), IP65	AL.; PF 3/4"(F), IP65	AL. ; PF 1/2"(F), IP66	
Combination unit	HLC-200A, HLC-300N, or HLC-400			



It is recommended that the HR-30 Series work with our Combination unit.

Specifications Applied to the Float

Float	Environment						
	Temp. (°C)	Press. (kg/cm ²)	Acid	Alkaline	Oil	Solvent	Liquid gas
SUS316L	-20 ~ +150	Up to 20	△	○	○	◎	△
PVC	-10 ~ +60	0.5	○	○	X	△	X
TEFLON	-20 ~ +150	Up to 0.5~3	◎	◎	X	○	△
NBR	-48 ~ +60	Up to 20	X	△	◎	△	○
TITANIUM	-20 ~ +150	Up to 10	X	△	◎	△	○

Note: ◎ – Excellent, ○ – Good, △- Acceptable, X- Not good



The application specification may vary depending on the specific measurement and the specific gravity.

**Contact
Point
Capacity**

SPST

Float	Enclosure	Max. Switch Voltage	Max. Switch Current
1"	Weather-proof	DC 24V	0.5A
	Ex-proof		
2", 3", 4"	Weather-proof	AC 250V / DC 24V	1A/0.5A
	Ex-proof		

SPDT

Float	Enclosure	Max. Switch Voltage	Max. Switch Current
1", 2"	Weather-proof	DC 24V	0.25A
	Ex-proof	DC 24V	0.2A
3", 4"	Weather-proof	AC 250V / DC 24V	1A/0.5A
	Ex-proof		

Latching Switch

Float	Enclosure	Max. Switch Voltage	Max. Switch Current
1", 2"	Weather-proof	DC 24V	0.25A
	Ex-proof		
3", 4"	Weather-proof	AC 250V / DC 24V	1A/0.5A
	Ex-proof	AC 110V / DC 24V	

**Contact
Form**

Float	Max. Contact form	
1"	4-SPST	2-SPDT
2"	6-SPST	3-SPDT
3"	6-SPST	4-SPDT
4"	6-SPST	4-SPDT

**Minimum
Section Distance**

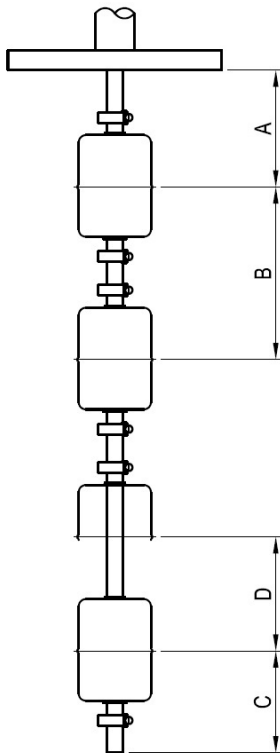

Stainless Steel

Standard Type	Float Size			
	1"	2"	3"	4"
Section A(mm)	40	50	100	100
Section B(mm)	55	80	160	170
Section C(mm)	40(100)	50(100)	100	100

Latching Type	Float Size			
	1"	2"	3"	4"
Section D(mm)	20			

PVC

Standard Type	Float Size		
	2"	3"	4"
Section A(mm)	60	100	100
Section B(mm)	110	150	150
Section C(mm)	60(100)	100	100

Latching Type	Float Size		
	2"	3"	4"
Section D(mm)	20		

TEFLON

Standard Type	Float Size			
	1"	2"	3"	4"
Section A(mm)	40	50	100	100
Section B(mm)	55(120)	80(120)	180	180
Section C(mm)	40(100)	50(100)	100	100

Latching Type	Float Size			
	1"	2"	3"	4"
Section D(mm)	20			

- A = Upper Dead Band: Minimum length which cannot be measured from the bottom of flange
- B = Minimum distance between two setting points
- C = Lower Dead Band: Minimum length which cannot be measured from the end of guide pipe
- D = Minimum distance between two setting points for detecting by one float
- () = Minimum distance between two setting points for A/B alarm (@Section B)
Lower Dead Band for latching type (@Section C)

**Float
Application
Table**

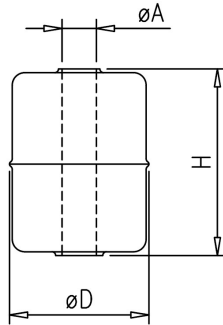

Product	Size	Dimensions(mm)			Guide Tube	Material	(*)S.G Range
		D	H	A			
HR-30S HR-30C	1"	Ø28	28	Ø9.5	Ø8	316L	0.9~1.4
		Ø26	15	Ø9.5	Ø8	Foam NBR	0.8~1.3
	2"	Ø49	50	Ø15.5	Ø12.7	316L	0.7~1.0
		Ø50	45	Ø20	Ø15.8	Foam NBR	0.6~0.9
		Ø42	50	Ø15	Ø12.7	316L	0.8~1.3
HR-30S	3"	Ø73	105	Ø23.5	Ø21.7	316L	1.0~1.5
		Ø73	108	Ø23	Ø21.7	Titanium	0.6~0.9
		Ø65	90	Ø25	Ø21.7	316L	0.9~1.5
	4"	Ø95	119	Ø30	Ø25.4	316L	0.8~1.3
		Ø95	103	Ø23	Ø21.7	Titanium	0.6~0.8
		Ø95	118	Ø23	Ø21.7	Titanium	0.5~0.6
		Ø80	80	Ø28	Ø25.4	Foam NBR	0.5~0.7

Product	Size	Dimensions(mm)			Guide Tube	Material	(*)S.G Range
		D	H	A			
HR-30V	2"	Ø49	60	Ø20	Ø18	PVC	1.0~1.6
	3"	Ø76	110	Ø31.5	Ø26		1.0~1.6
	4"						

Product	Size	Dimensions(mm)			Guide Tube	Material	(*)S.G Range
		D	H	A			
HR-30T	1"	Ø26	30	Ø10.5	Ø10	TEFLON	1.1~1.7
		Ø28	35	Ø11	Ø10	TEFLON	1.1~1.7
		Ø28	30	Ø11	Ø10	PP	1.0~1.7
	2"	Ø45	50	Ø17	Ø15	TEFLON	0.9~1.6
							1.1~1.7
	3&4"	Ø69	96	Ø23.5	Ø21	TEFLON	0.8~1.3
							0.9~1.5
	4"	Ø85	100	Ø33	Ø28	TEFLON	1.1~1.7

(*)S.G: Specific Gravity

**Product
Composition**

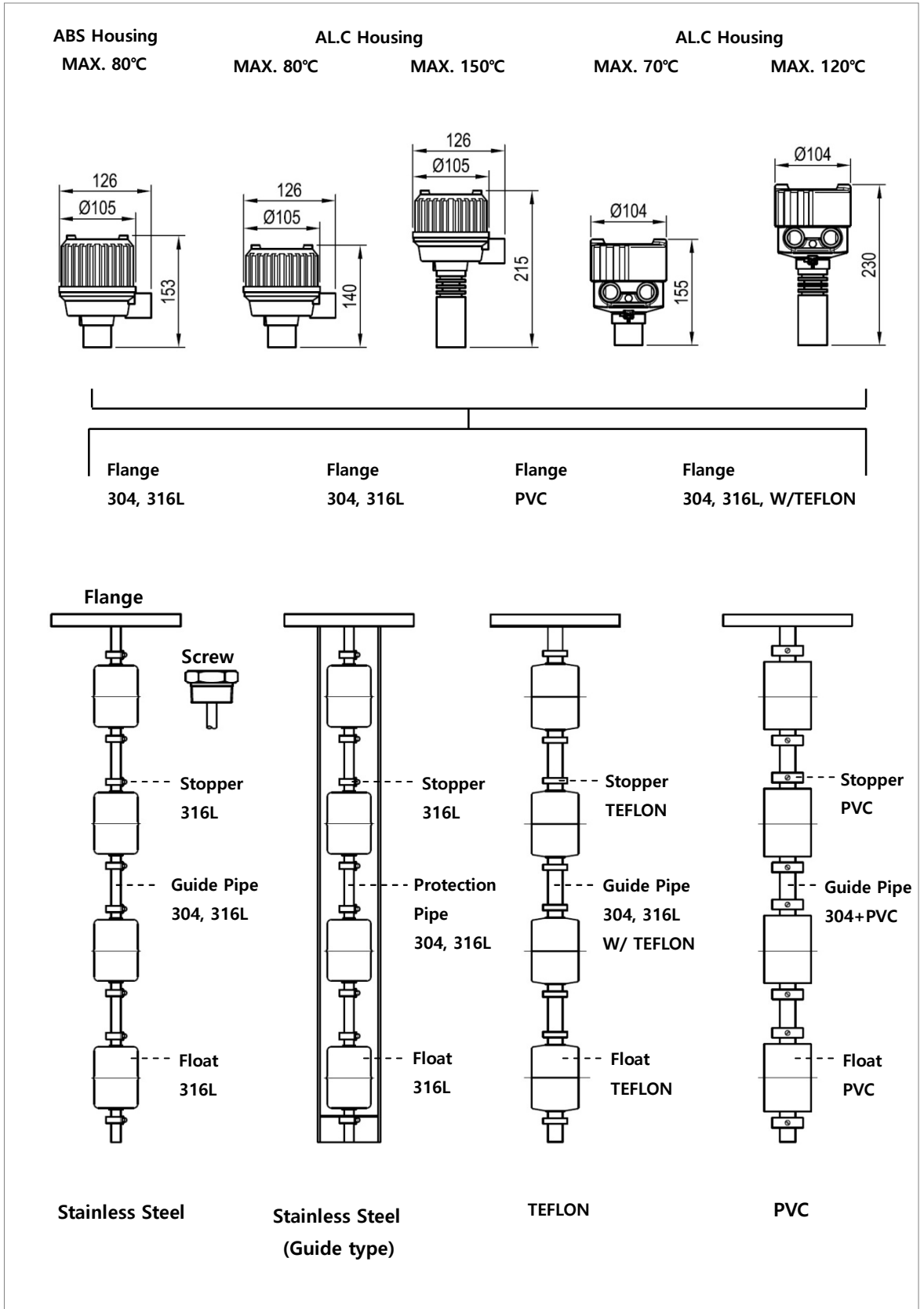

Dimension

<WEATHER-PROOF Version>

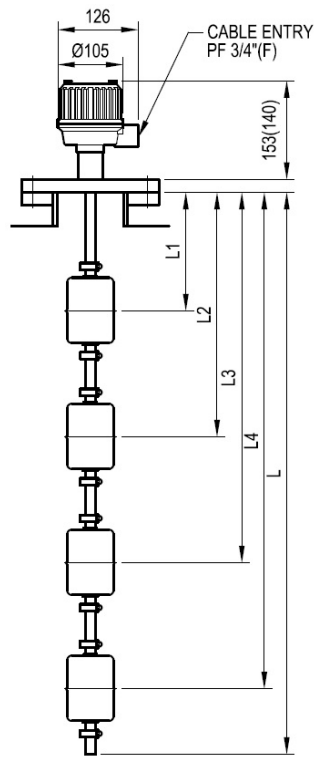

HR-30S

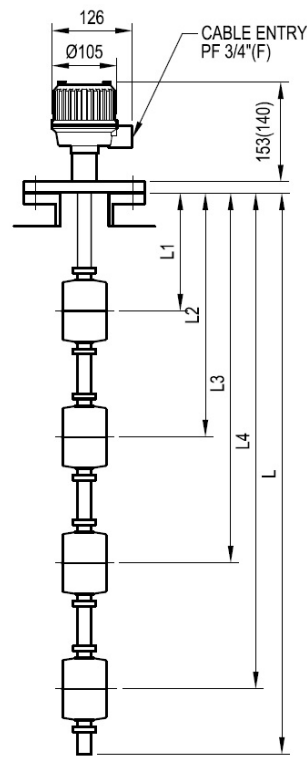

HR-30T

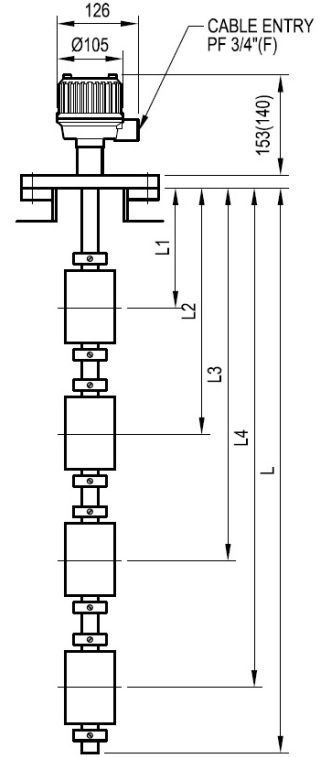

HR-30V

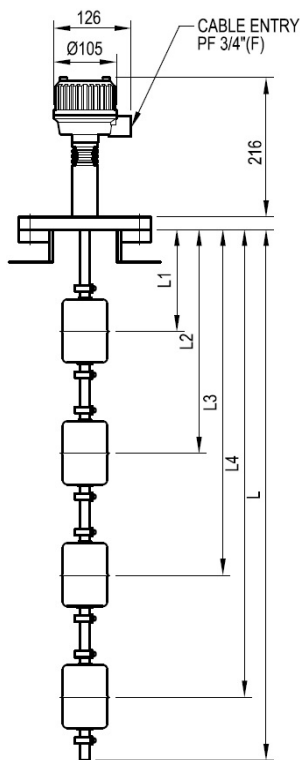

HR-30SH

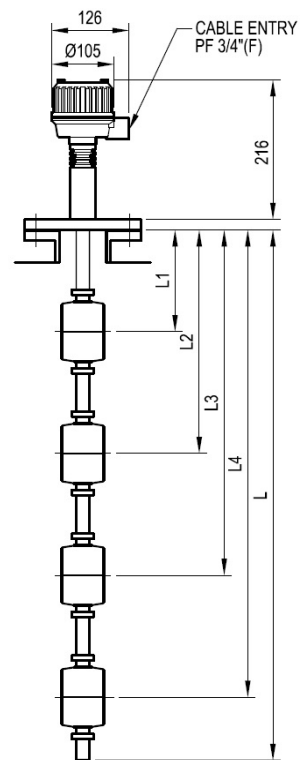

HR-30TH

<Ex-PROOF Version>

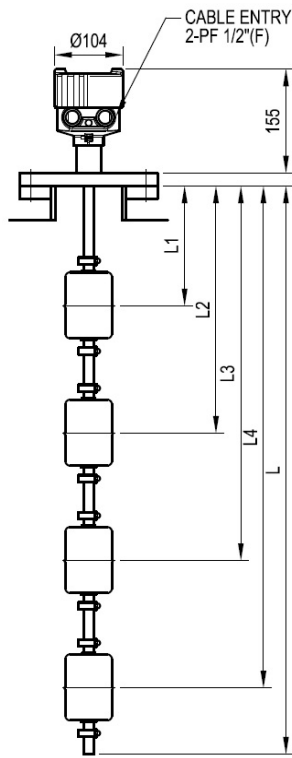

HR-30S-EX

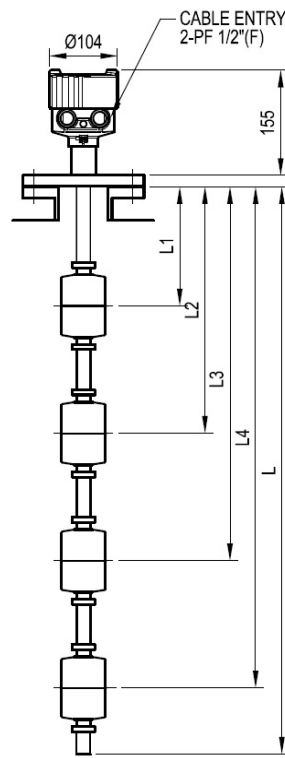

HR-30T-EX

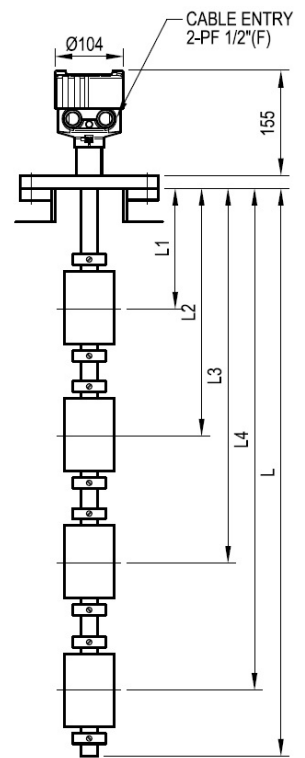

HR-30V-EX

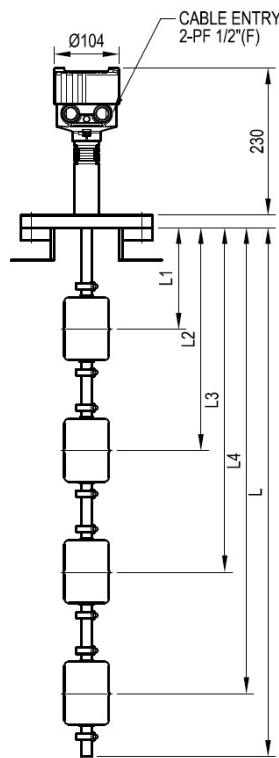

HR-30SH-EX

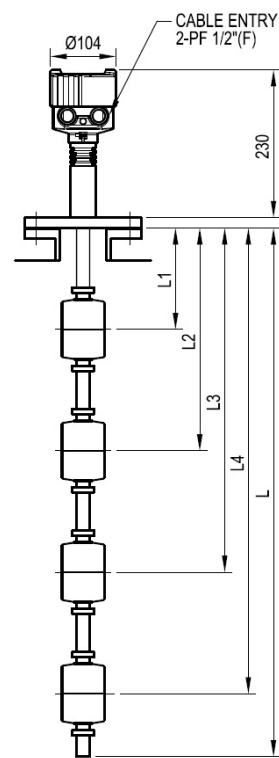

HR-30SH-EX

<FLAP TYPE LEVEL GAUGE with HR-30 Series>

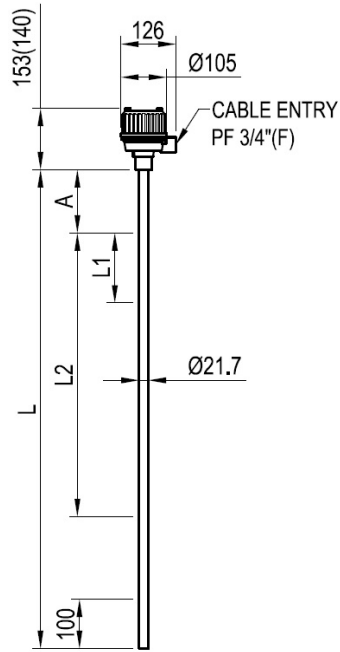

HR-30

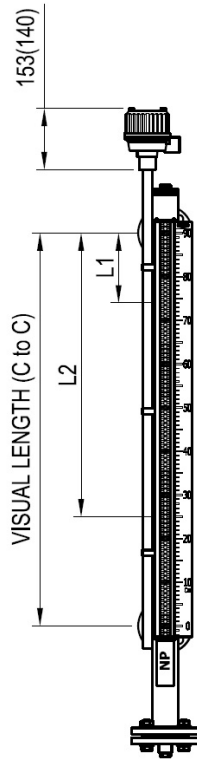

HR-30+HLG-100F

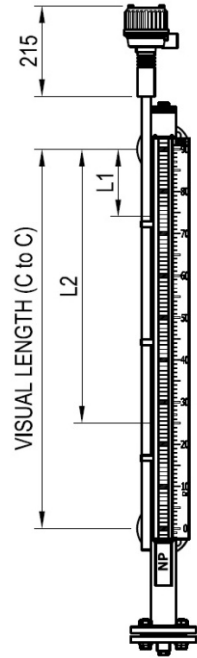

HR-30H+HLG-100F

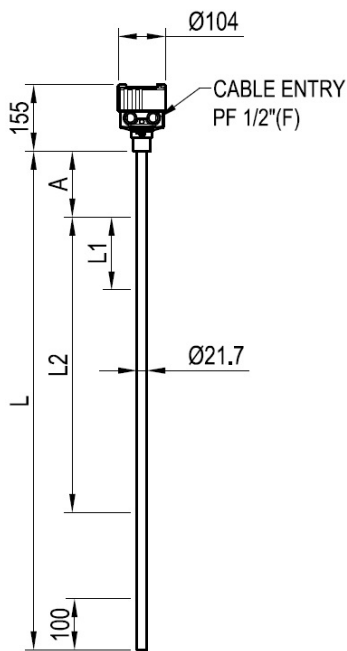

HR-30-Ex

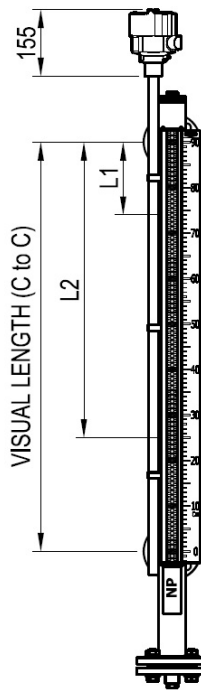

HR-30-Ex+HLG-100F

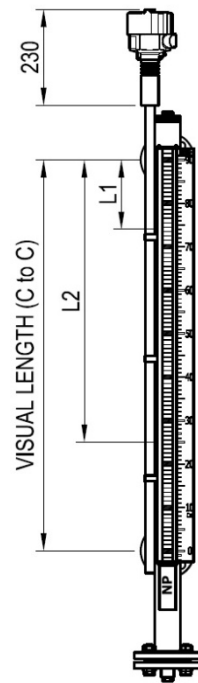

HR-30H-Ex+HLG-100F



VENT PLUG : A=180mm
 NOTICE VENT VALVE /w PLUG : A=250mm

Maintenance

The major parts of HR-30 Series to be inspected are float and reed switch. The life span of key parts depends on user's environment and can be used optimally through periodic check. Therefore, regular inspection ensures optimal performance of product, so take regular inspection and maintenance at least every year. In addition, check for the exterior of the product like visual damage. If there is scale caused by measurements, it shall be removed for the smooth operation of the float. Reed switch can simply be inspected using a Digital Multimeter as follow.

- Select the buzzer of the Digital Multimeter and connect it to one of product's terminal blocks, E1~E4, and the COM terminal.
- If the buzzer rings when the float reaches the upper/lower contact points, it works normally.
- If the contact state is checked by resistance, the Digital Multimeter indicates 0Ω by moving the float, it is normal to the N.C (Normal Close), and the N.O (Normal Open) indicates infinite.



Please turn off the power of the product for maintenance.

Precautions for Removal

- Check the level and presence of measurements in the tank before removing it.
- Wear gloves when removing it, to prevent a burn.
- Disassemble work shall be done with the power off.
- If there is explosive gas atmosphere, do not open the cover.
- Unlock the lock key (Set screw) before removing the cover. (Ex-proof)
- Make sure that any O-ring or gasket is not damaged while opening or closing the cover of product.

Precautions for Installation

- Use the same standard flange or screw.
- Make sure to insert washers between bolts and nuts to prevent loosening.
- When you attach the product to a hopper, make sure that it is as bonded as possible by means of tools.
- Make sure to insert gaskets between flanges. (Select the gaskets in consideration of temperature of content and pressure of vessel.)
- Install an Ex-proof product only in an Ex-proof zone.
- After the installation is complete and the cover of the product is assembled, power it on.



Please do not apply high impact to the product.

Precautions for Inserted External Wire (Ex-proof)

- Use the cable gland connection or metal pipe line lead-in on the wire inlet, and use a product with equivalent Ex-proof certificate to connect it with the external line lead-in method.
- For non-use external wire inlet, use a closed plug that passes safety certificate above equivalent performance with the product.

**Precautions
for
Grounding
(Ex-proof)**

- The grounding has an external and an internal grounding. When connecting to an external ground, the ground wire shall be 4mm² (4mmSQ).
- The internal grounding wire shall be the same size as the power line, and the size of the internal grounding terminal lug shall be 3.1mm² (3.1mmSQ). If the power line is larger than 3.1mm², connect the ground wire without terminal lug.



Make sure to insert a washer if the terminal lug is removed from ground terminal and then re- connected. (Loosening prevention)

**Precautions
for
Attachment**

Below recommendation shall be considered when installation.

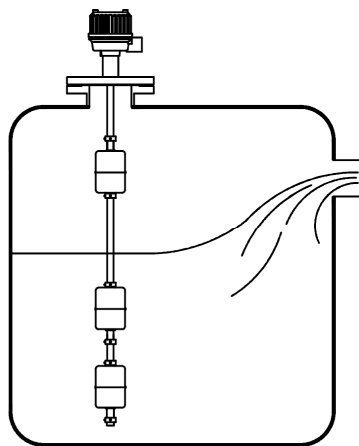

Product shall be installed at the place far from inlet in order to avoid the malfunction.

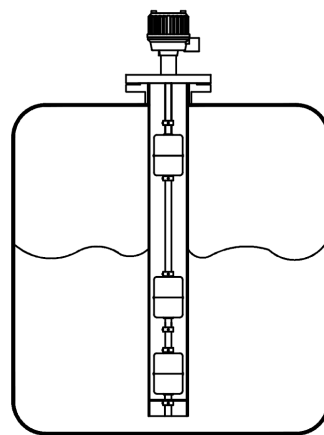

Protection tube shall be applied if there is a flow or slopping of the medium in the tank.

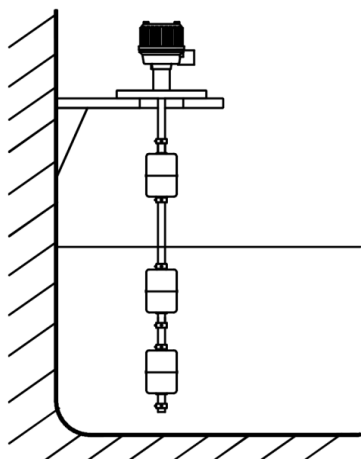

Bracket shall be installed with the product when the installation on the concrete as per above figure.

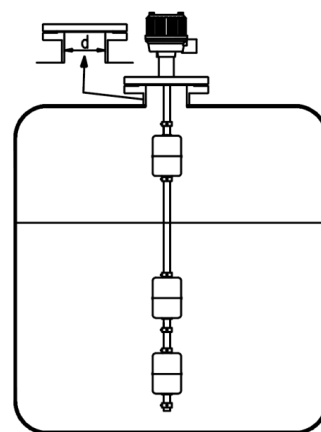



Inner diameter "d" of tank nozzle shall be larger than the outer diameter of float as per above figure.

Wiring

The terminals of the products are composed according to contact points and shall be connected as follows.

- Open the cover and insert the cable through the wire inlet.
- Identify the contact points (E1, E2 ...) on the terminal block and connect the cable.

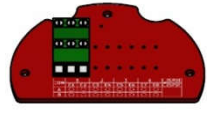
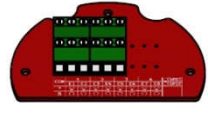
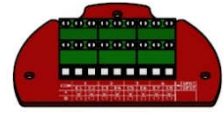
Weather-Proof 						
Ex-Proof 						
						
	SPST	1F ~ 2F	SPST	3F ~ 5F	SPST	6F
	SPDT	1F	SPDT	2F	SPDT	3F ~ 4F

■ Contact Form notation

COM	1	2	3	4	○ SPDT				
	E1	E2	E3	E4	E5	E6	E7	E8	○ SPST
A	○	○	○	○	○	○	○	○	
B	○	○	○	○	○	○	○	○	

Ex) 3-SPST A Contact order indication

COM	1	2	3	4	○ SPDT				
	E1	E2	E3	E4	E5	E6	E7	E8	○ SPST
A	●	●	●	○	○	○	○	○	
B	○	○	○	○	○	○	○	○	

Ex) 3-SPDT order indication

COM	1	2	3	4	○ SPDT				
	E1	E2	E3	E4	E5	E6	E7	E8	○ SPST
A	●	○	●	○	●	○	○	○	
B	○	●	○	●	○	●	○	○	

Matters regarding Operation and Use

The Product can be manufactured to N.O (Contact with A)/N.C (Contact with B) on orders from customers, and if there are no specific requirements for them, it can be manufactured to N.O (Contact with A). The shape of the contacts is shown below.

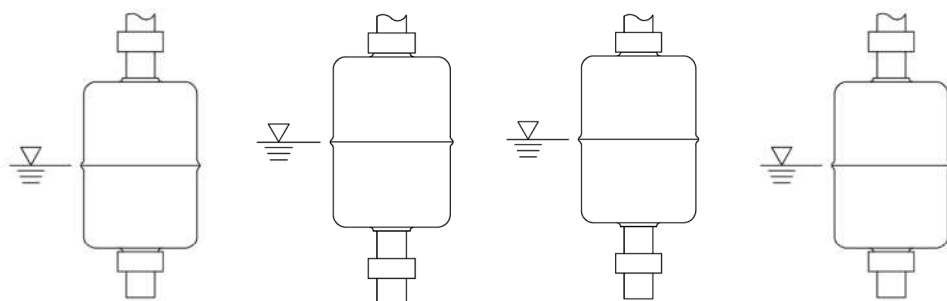

Contact with A (OFF)

Contact with A (ON)

Contact with B (OFF)

Contact with B (ON)

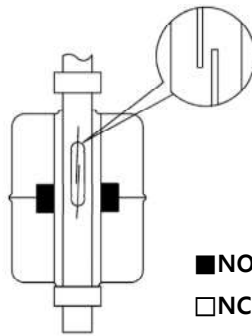

Switch ON, when the level rises. (Contact with A)

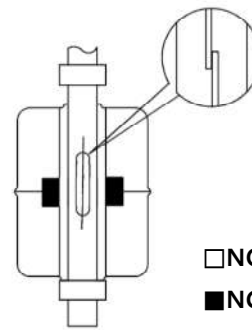

Switch ON, when the level drops. (Contact with B)



Please do not move the stopper holding the float at random.

Safety and Environment

■ Precautions for Use

- Make sure to connect the product and vessel using required tools for sure.
- Keep the lock key safe and make sure that it is locked.
- Do not apply high impact to the product.

■ Precautions for Wiring

- Make sure to wire contacts correctly (refer to Wiring)
- Internal ground (inside product housing) and external ground shall be connected.
- Pay attention to prevent electric shock.

■ Disposal of Product

- Make sure to separate the amplifier and main unit from housing before disposing the products. Also, the amplifier shall be detached and discard the metal and non-metallic materials. No part (ex. Mercury switch) has influence on the environment, so no special attention is required.

Marking

■ Product Identification

- The product identification mark is attached onto the housing and shows the model name, serial number, working temperature, working pressure, and matters regarding output. The serial number is a unique manufacturing number for the identification of products.



<Weather-proof>

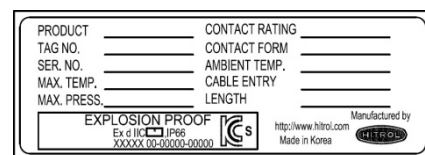

<Ex-proof>

User Training

The fluid temperature of the container shall be up to 80°C for Weather-proof type. For high temperature, the fluid temperature shall not exceed 150°C and the surface temperature of the product installed in the container shall not exceed 85°C(T6 grade).

In addition, make sure that the ambient temperature of housing is kept at -20°C ~ +60°C. (However, product with PVC sensor part, the fluid temperature of the container is limited to 60°C.) An Ex-proof product is a pressure-resistant and Ex-proof type, so never open the cover during operation. Ex-proof products are designed according to Article 34 of the Industrial Safety and Health Act and Article 58.4 of the Enforcement Rules of the same Act.



Do not apply the Non Ex-proof product in an Ex-proof zone.

The Ex-proof product can be used where the environment and liquid inside the containers are of zone 1 and 2

Warranty and Contact

■ Warranty and Service

This product is subject to the warranty for 2 years of shipment and unpaid service will be provided for any damage found under normal operating conditions. If it is not about the failure of product, the service charge will be payable.

You can request A/S at our website or by contacting our headquarters.



PTFE Float and Tube have a warranty period of one year after the product is shipped.

■ Headquarters . Factory . Laboratory Contact Number

ADDRESS: HITROL CO., LTD 141, Palhakgol-gil, Jori-eup, Paju-si, Gyeonggi-do, Korea

T E L : 031-950-9700 (Headquarters & A/S)

F A X : 031-943-5600 (Headquarters & A/S)