

HITROL CO., LTD.

HEAD OFFICE.FACTORY.R&D INSTITUTE
HITROL CO., LTD. 141, Palhakgol-gil, Jori-eup
Paju-si, Gyeonggi-do, Korea
TEL. : (+82)-31-950-9700
FAX. : (+82)-31-943-5600
www.hitrol.com



INSTRUCTION MANUAL

TANK LEVEL GAUGE

HFW-100W Series

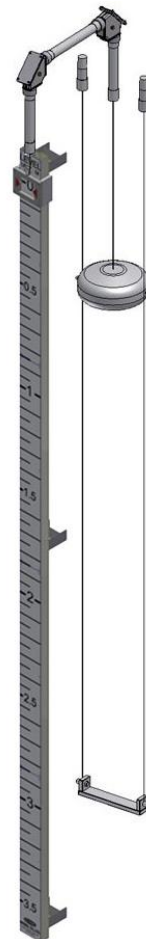

Doc. no. : HFW100W_IM_Eng_Rev. 0

Issue date : 2020. 11

Table of Contents

Overview.....	3
Characteristics	3
Operating Principle.....	3
Specifications	3
Product Composition and Technical Data.....	4
Installation.....	7
Precautions for Installation	8
Maintenance	9
Other Precautions.....	9
Warranty and Contact.....	10



You should be well-informed where **WARNING** is marked before carrying out the work.



You should be careful where **CAUTION** is marked to carry out the work.



You should be aware of where **NOTICE** is marked to carry out the work.

Overview The *HFW-100W Series* is a target type tank level gauge used to measure and instruct the level of large tanks in various industrial facilities, including oil, petrochemicals, food, chemicals, water treatment facilities and power plant, using the weight balance of float and weight. It is mostly used, particularly, in checking storage, maintaining constant water levels, and measuring certain amounts of liquids in batch processes.

- Oil refining: Crude Oil, Gasoline, Heavy Oil, Lamp Oil, Naphtha, Organic Oil, Inorganic Oil, Asphalt Pitch, Sulfur
- Petrochemicals: Benzol, Toluene, Xylene, Methanol, Ethanol
- Dam: Water Gauge, Gate Opening Indicator, etc.
- Food: Beer, Liquor, Soy Sauce, Molasses, Mayonnaise
- Chemicals: Paint, Caustic Soda, Hydrochloric Acid, Sulfuric Acid
- Power Plant: Heavy Oil, Water Tank, Distillation tank
- Water Treatment: Waterworks and sewage facilities, waste water, drinking water, Elevated Water Storage Tank

Characteristics

- Simplified design with high durability
- Easy calibration

Operating Principle The float on the liquid surface in the tank floats at the point where the weight of the float, the buoyancy of the float and the weight maintain their equilibrium. If the water level rises or falls, the level scale indicated by the weight becomes the measurement level when the force of the rise or fall due to the buoyancy variation of the float is balanced with the weight.

Specifications

Product	HFW-100W
Installation	Side Mounting
Measuring Range	Max. 6m
Measuring Unit	Meter
Ambient Temperature	-20°C ~ 80°C
Fluid Temperature	Max. 150°C
Operation Pressure	ATM
Minimum Scale	50mm (Std.)
Process Conn. Size	Screw Type: PT 1"(F) Socket (Std.)

Product ■ HFW-100W

**Composition
and
Technical
Data**

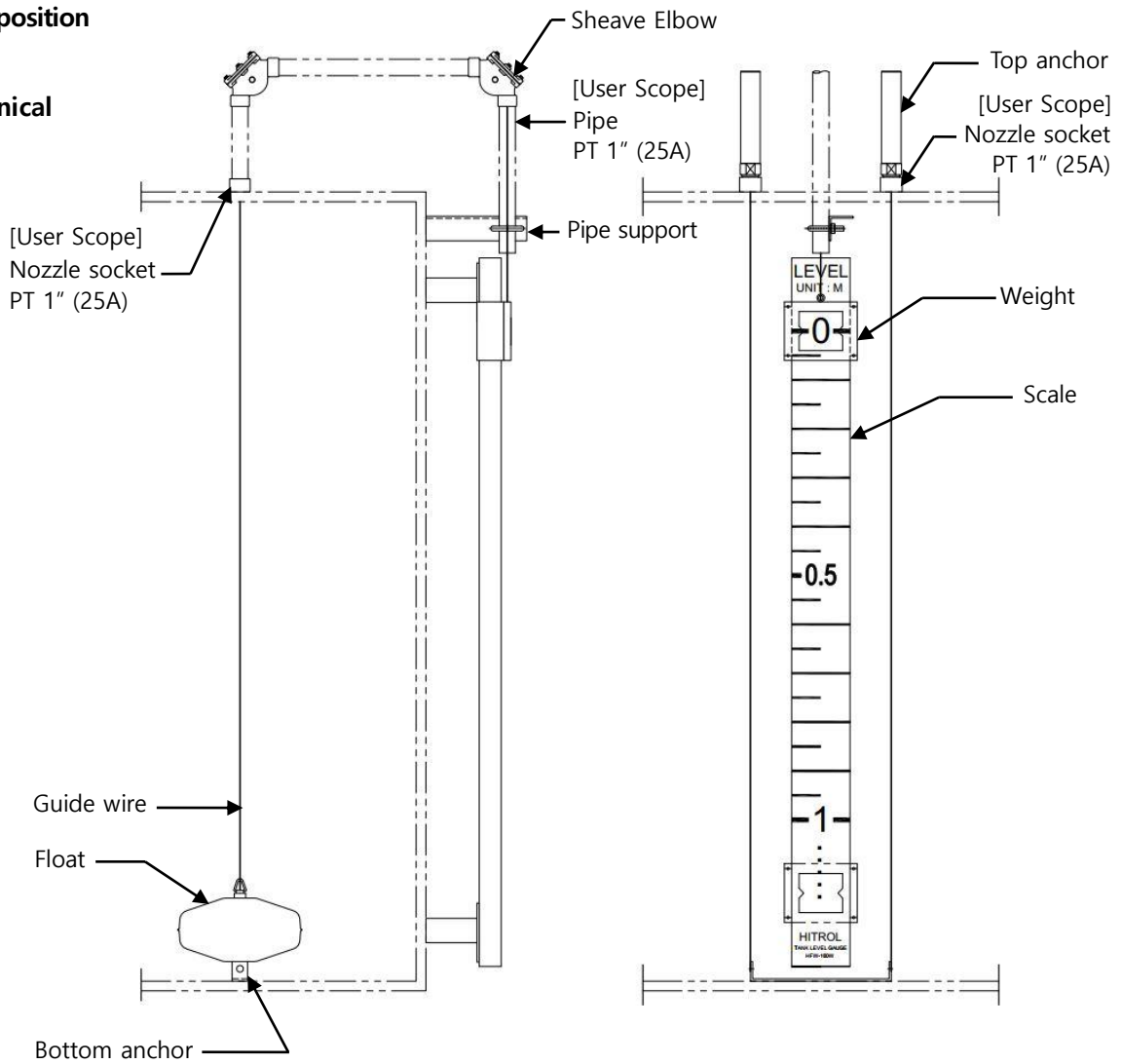

■ Part Name and Dimensions

The dimensions on the following pages are indicated in [mm]

[Part]

Sheave elbow (AL)

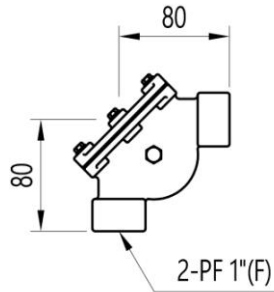

Weight (C.S+AL)

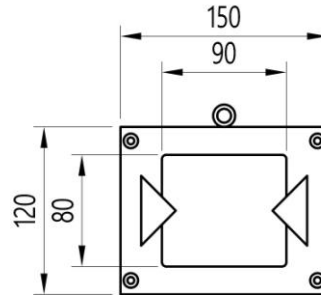

Top anchor

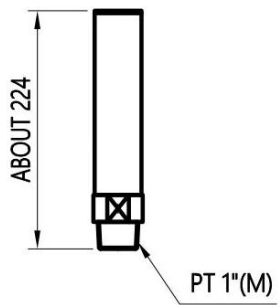

Bracket

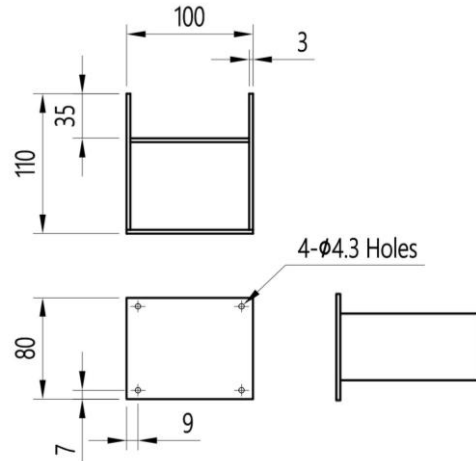

Pipe support

* CUT ACCORDING TO FIELD CONDITIONS.

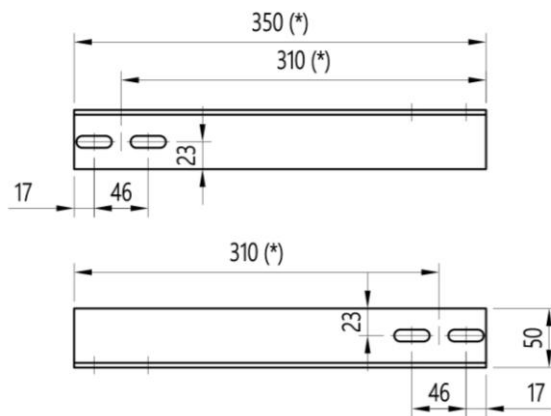

U-bolt

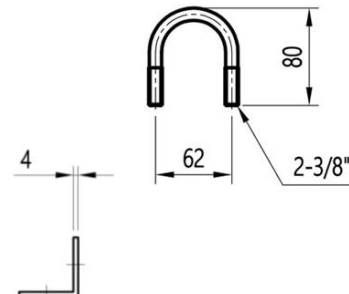

Some tolerances may occur with actual products.

Bottom anchor

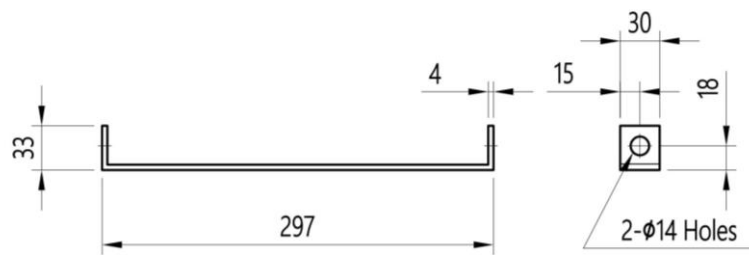

Float

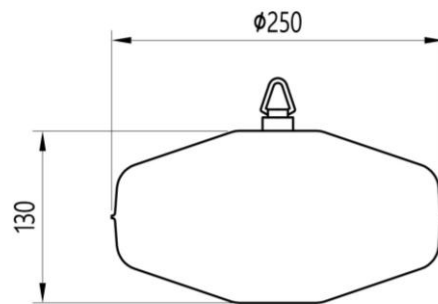

U-seal pot (CS+AL)

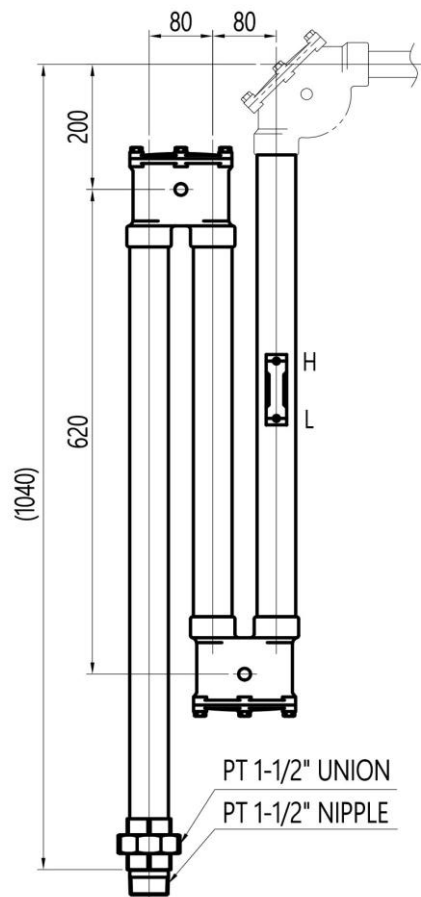

U-seal pot (SUS)

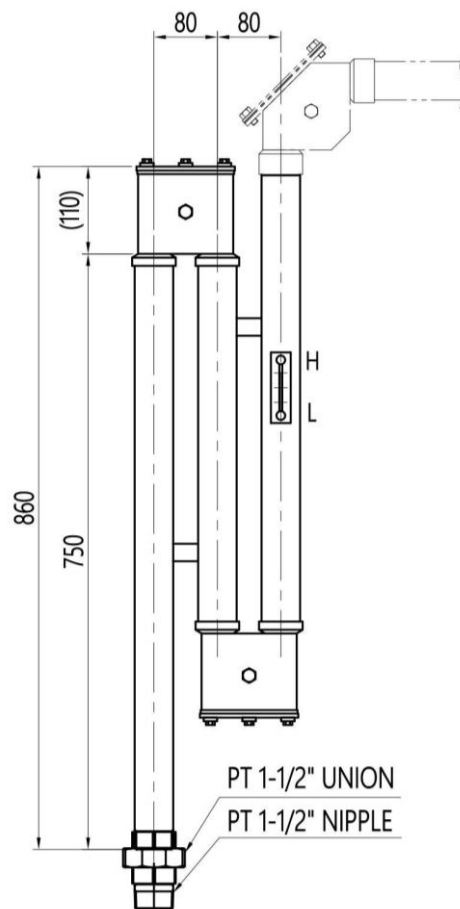

Some tolerances may occur with actual products.

Installation

■ Conditions for Installation and Adjustment

- 1) Make sure that the pipes and bottom anchor are ready.
- 2) It doesn't matter if the pipes and sheave elbow are installed first.
- 3) The inside of the tank shall be empty and there shall be no interference in instrument installation.
- 4) The nozzle of the tank shall be installed in accordance with the connections and specifications of product and shall be no risk of work inside.
- 5) There shall be no fluid leaks.
- 6) The environment shall be in place to ensure that installation and adjustment can be performed safely.
- 7) If used in toxic gases, the U-seal pot shall be used as the product damage and fluid leaks can occur.

■ Installation Sequence

1. Install the top anchor.
2. Install the guide wire.
 - 2-1) Open the cover of the top anchor at the top of the tank.
 - 2-2) After inserting the guide wire from the top anchor, leave the end of the guide wire about 100mm and tighten it to Nut① and Nut② to fix it to the top anchor. Refer to [Fig. 1-a]
 - 2-3) Insert the guide wire into the guide ring of the float at the bottom of the tank and fix the guide wire to bottom anchor using bolts and nuts. Refer to [Fig. 1-b].
 - 2-4) Cut and bend the end of the guide wire to prevent the float being caught.
 - 2-5) Tighten Nut③ to adjust the tension of the guide wire. Refer to [Fig. 1-c].
3. Install the pipe support, bracket, weight, and scale.

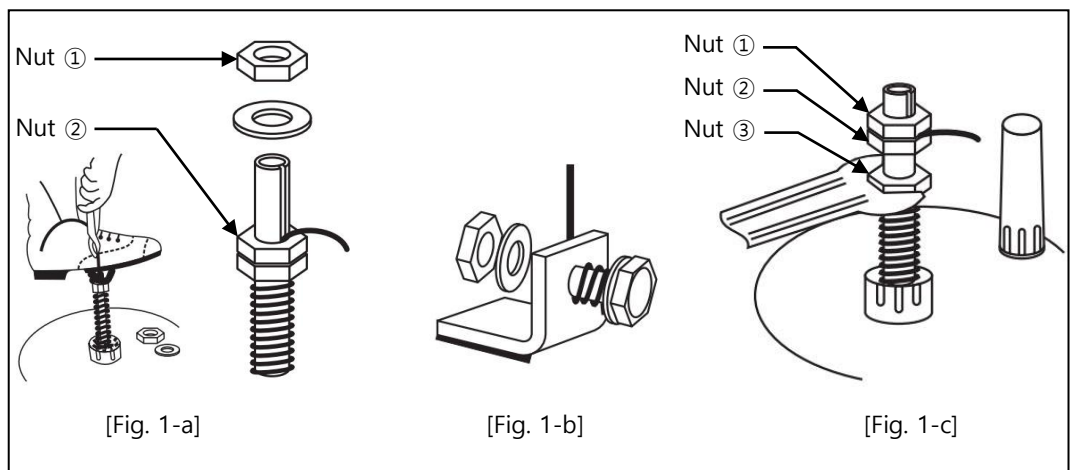

[Fig. 1] Guide wire Installation

**Precautions
for
Installation**

■ Pipe (User Scope)

- The pipe shall be galvanized or stainless.
- The bending degree of the pipe shall not be over than $\pm 5\text{mm}$ when installing. Refer to [Fig.2].
- If the contents of the tank are highly corrosive liquids, coated shall be used.
- When connecting pipes, ensure proper connection is made to prevent leakage of gas in the tank or rainwater from entering the tank. Refer to [Fig. 3].

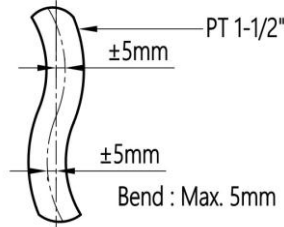

[Fig. 2] Pipe Material

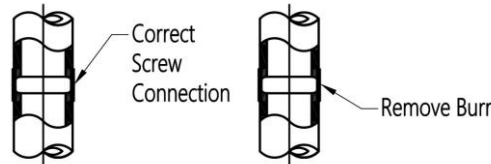

[Fig. 3-1] Proper Pipe-Screw Connection

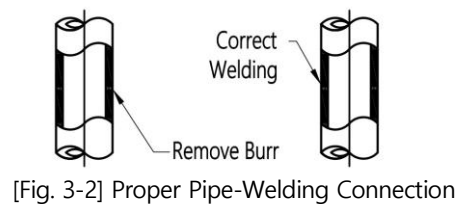

[Fig. 3-2] Proper Pipe-Welding Connection

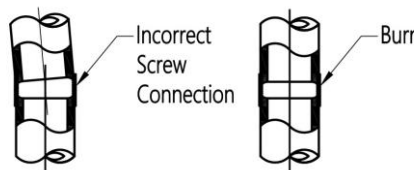

[Fig. 3-3] Wrong Pipe-Screw Connection

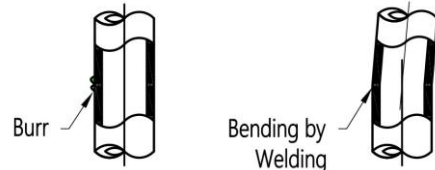

[Fig. 3-4] Wrong Pipe-Welding Connection

■ Float

- Make sure that the float is installed upwards on the side where the guide wire is connected.
- The position of the float shall be located away from the inlet of the fluid entering the tank to prevent the float from being affected by the fluid flow or swirling. If the float is inevitably to be installed at the inlet of the fluid, the guide pipe shall be installed to protect the float. Refer to Fig. 4]

Recommended Installation

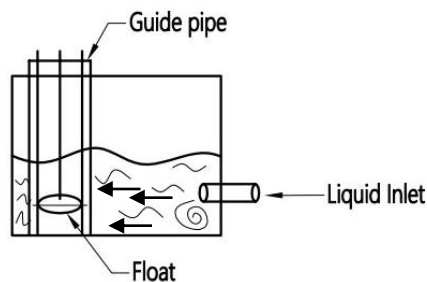

Not Recommended Installation

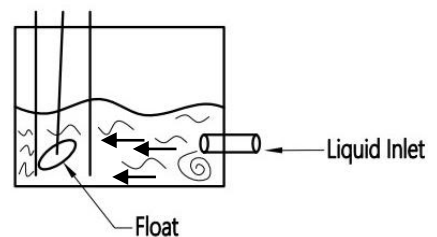

[Fig. 4] Float Installation Site

■ Top anchor, Guide wire

- Hang the anchor on the guide wire and set the location of the bottom anchor. Ensure that the top anchor and flange are positioned vertically to each other. Refer to [Fig. 5]
- Since the distance between the bottom anchor and guide wire is 290mm, the distance from the center line of the top anchor shall be set to 290mm.

Recommended Installation

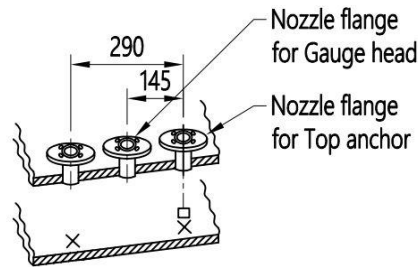

Not Recommended Installation

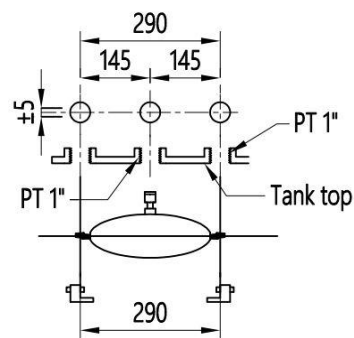
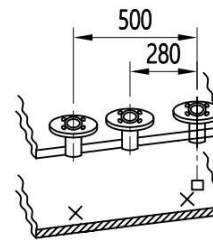

[Fig. 5] Top anchor Installation Cautions

Maintenance

The life of the key parts depends in user's environment and can be used optimally through periodic checks. Therefore, the user shall perform periodic maintenance at least once a year. When using the U-seal pot, make sure that the oil (Silicon oil) is charged inside. When used in highly viscous liquids, the float is covered with foreign substances, which results in a difference in buoyancy, and shall be cleaned periodically.

**Other
Precautions**

■ Precautions While Using

- Check the level and presence of the medium in the tank before disconnecting the product.
- Seal properly the screws and packing parts during installation to prevent leakage of the product.
- Be careful not to damage the packing or gasket parts when assembling/disassembling the product.
- Disassembly is performed in the reverse order of installation.

■ Disposal of the Product

- If the product is not available and need to be discarded, separate it according to the material and discard.



Do not apply high impact to the product.

**Warranty
and
Contact**

■ Warranty and Service

This product is subject to the warranty for 2 years of shipment and unpaid service will be provided for any damage found under normal operating conditions. If it is not about the failure of product, the service charge will be payable.

You can request A/S at our website or by contacting our headquarters.

■ Headquarters . Factory . Laboratory Contact Number

ADDRESS: HITROL CO., LTD 141, Palhagol-gil, Jori-eup, Paju-si, Gyeonggi-do, Korea

T E L : 031-950-9700 (Headquarters & A/S)

F A X : 031-950-9796~9 (Headquarters & A/S)