

FLOAT TYPE LEVEL SWITCH

# HIM-12 Series

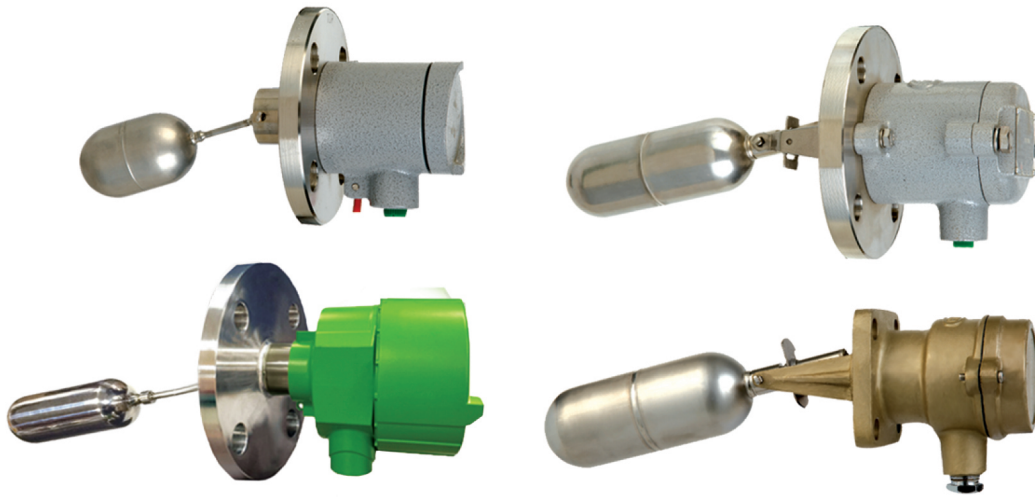

2 YEARS WARRANTY



ASME



[www.hitrol.com](http://www.hitrol.com)



Always The Best Solution

HITROL CO., LTD.

## 개요 | Overview

HM-12 Series는 탱크 측면에 설치하여 탱크내의 수위를 측정하고 스위치 접점의 ON / OFF신호로 급수 또는 배수시에 경보 및 제어 공정에 사용된다. 이 검출기는 구조가 견고하고 수명이 길다는 장점을 가지고 있으며 제품은 용도에 따라 일반 타입과 방폭 타입 두 가지가 있다.

## 특징 | Characteristics

- 여러종류의 액체 레벨을 검출할 수 있다.
- 구조가 견고하고 수명이 길다.
- 고온 용기에도 사용할 수 있다.
- 다양한 형태의 부식성을 가진 측정물에 저항성을 가진 감지부 재질이 있다. (TEFLON)
- 내압방폭 타입으로 제작이 가능하다 (HM-12H-Ex).
- FLOAT와 스위치가 완전 분리되어 누설 문제가 없다.
- FLOAT의 내구성이 강하다.

## 동작원리 | Operation Principle

HM-12 series는 자석끼리 반발하는 힘을 이용하여 동작하는 계기로서 액위의 변화에 따라 Float가 상승하면 Float와 연결되어있는 샤프트의 자석이 Housing의 홀더자석과 반발되면서 마이크로 스위치를 동작시킨다. 접점은 레벨의 상·하한 경보로 사용할 수 있다.

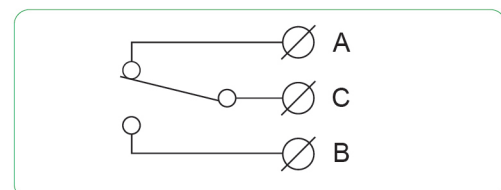
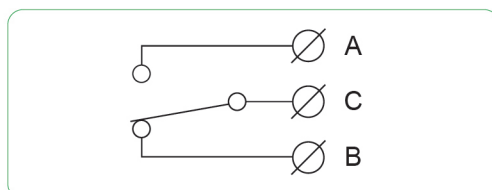
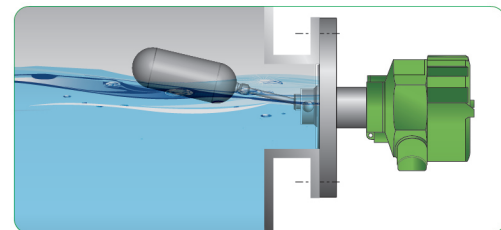
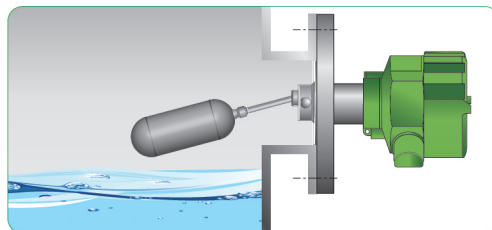
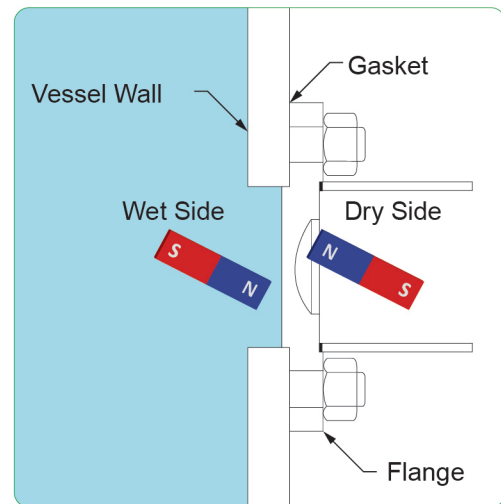
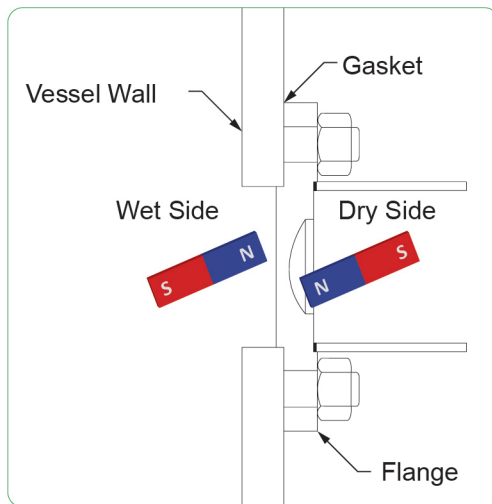

FLOAT TYPE LEVEL SWITCH  
**HM-12(10) series**

## 제품 사양 | Specification

Model	HM-12S	HM-12H	HM-12H-Ex	HM-12D
Mounting	Flange			Square Flange
Ambient Temperature	-20°C ~ +60°C		-20°C ~ +80°C	-20°C ~ +60°C
Process Temperature	Max. 120°C		T6 (Max. 120°C) T5 (Max. 80°C) T4 (Max. 70°C)	Max. 120°C
Process Pressure	Up to 10kg/cm <sup>2</sup> (150#)	Up to 20kg/cm <sup>2</sup> (300#)		Up to 10kg/cm <sup>2</sup> (150#)
Output Signal	1-DPDT		1-SPDT / DPDT	1-SPDT
Contact Rating	AC 250V, 10A DC 30V, 5A		AC250V, 15A DC125V, 0.5A	AC250V, 10A DC125V, 0.5A
Enclosure	Weather Proof (IP66)	Weather Proof (IP65)	Ex-Proof (Ex d IIC T4/T5/T6)	Weather Proof (IP65)
Wetted Part Material	SUS 316L			SUS 316L + B.S
Process Connection	40A JIS 10K RF (std.)	65A JIS 10K RF (std.)		Squares (92x92mm)
Housing Material	Aluminum		Aluminum + SUS 304	B.S
Cable Entry	PF 1/2"(F)			

HM-12(10) Series

Model	HM-12H-SP	HM-12H-SP-Ex	HM-12H-L	HM-12H-L-Ex
Mounting	Flange			
Ambient Temperature	-20°C ~ +60°C			-20°C ~ +80°C
Process Temperature	Max. 250°C	T3 (Max. 150°C) T2 (Max. 250°C)	Max. 120°C	T6 (Max. 120°C) T5 (Max. 80°C) T4 (Max. 70°C)
Process Pressure	Up to 20kg/cm <sup>2</sup> (300#)			
Output Signal	1-SPDT		1-DPDT	
Contact Rating	AC 125V, 5A AC 250V, 3A		AC 250V, 10A DC 30V, 5A	AC250V, 15A DC125V, 0.5A
Enclosure	Weather Proof (IP66)	Ex-Proof (Ex d IIC T2/T3)	Weather Proof (IP65)	Ex-Proof (Ex d IIC T4/T5/T6)
Wetted Part Material	SUS 316L			
Process Connection	65A JIS 10K RF (std.)		80A JIS 10K RF (std.)	
Housing Material	Aluminum + SUS 304		Aluminum	Aluminum + SUS 304
Cable Entry	PF 1/2"(F)			

▶ **ORDER CODES**는 당사 홈페이지 [www.hitrol.com](http://www.hitrol.com) 에서 출력하여 사용하실 수 있습니다.

## 외형도 | Dimension

HM-12S

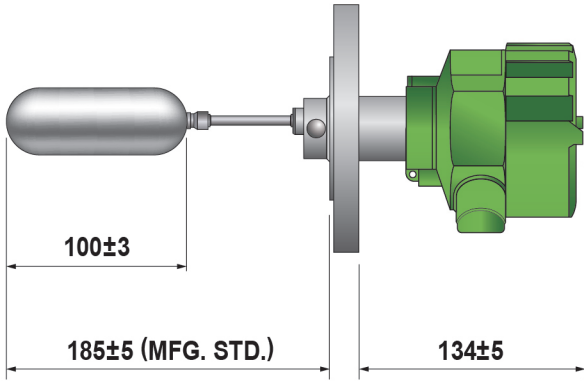

HM-12H

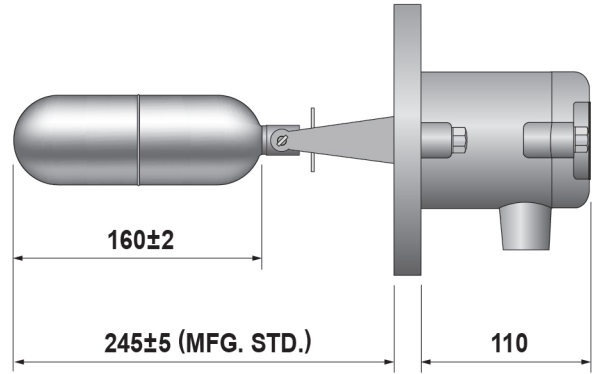

HM-12H-Ex

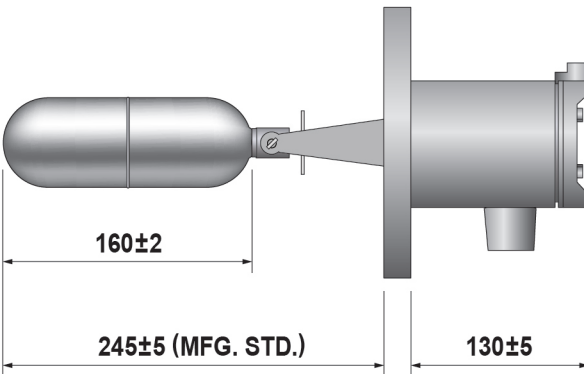

HM-12D

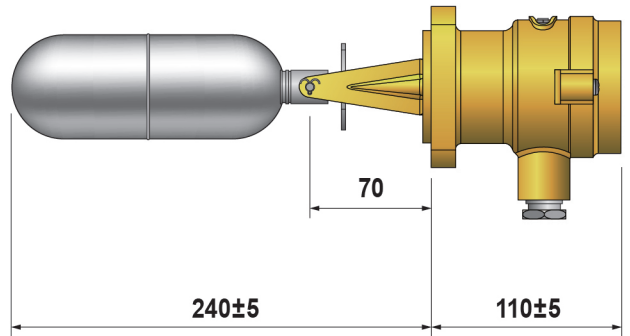

HM-12H-L

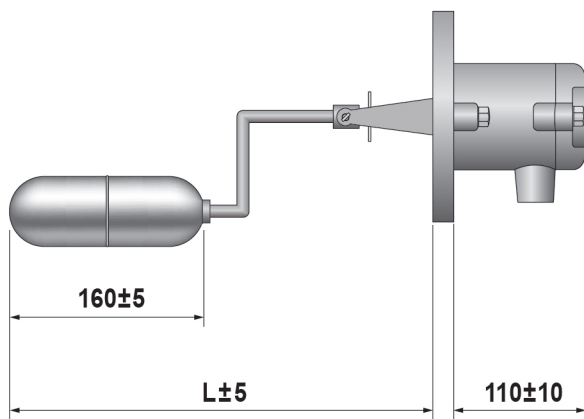

HM-12H-L-Ex

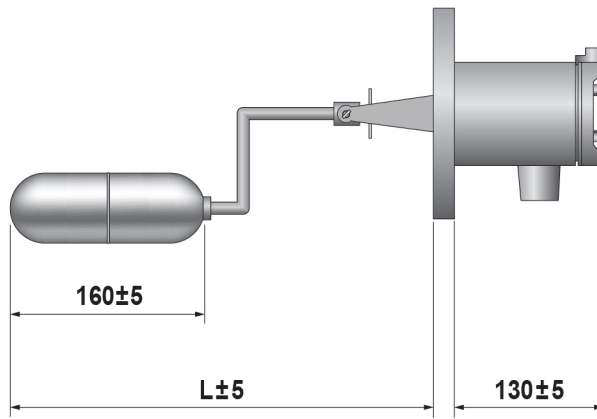

◆ 실제제품과는 약간의 공차가 발생할 수 있습니다.

HM-12H-SP

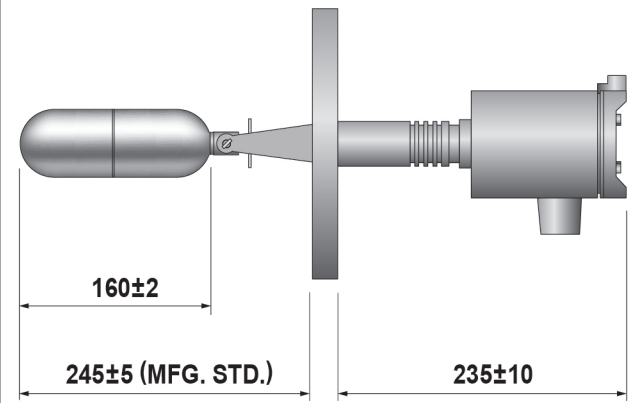

HM-12H-SP-Ex

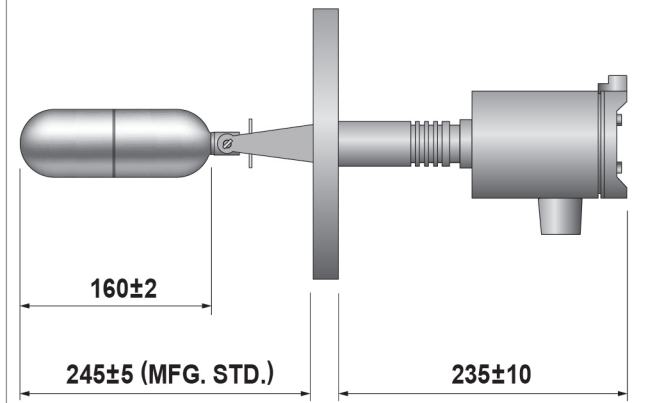

External Chamber

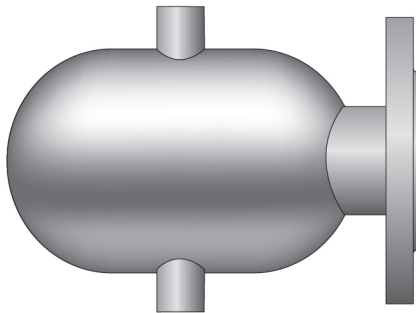

◆ 실제제품과는 약간의 공차가 발생할 수 있습니다.

## 적용 | Application

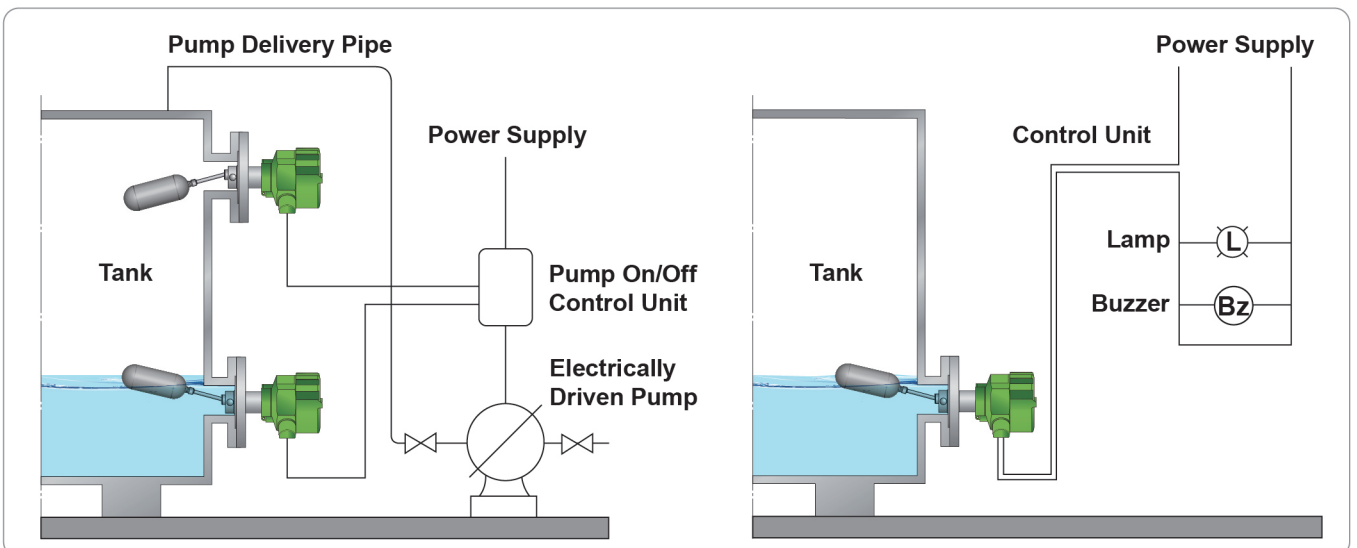



FLOAT TYPE LEVEL SWITCH

## HM-12 Series

01 다양한 APPLICATION

02 견고한 설계구조 및 높은 내구성

03 쉽고 편리한 설치



 [hitrol@hitrol.com](mailto:hitrol@hitrol.com)

 [www.hitrol.com](http://www.hitrol.com)

\* 제품은 업그레이드를 위하여 예고 없이 변경될 수 있습니다.