

FLOAT TYPE LEVEL SWITCH

HIM-12 Series

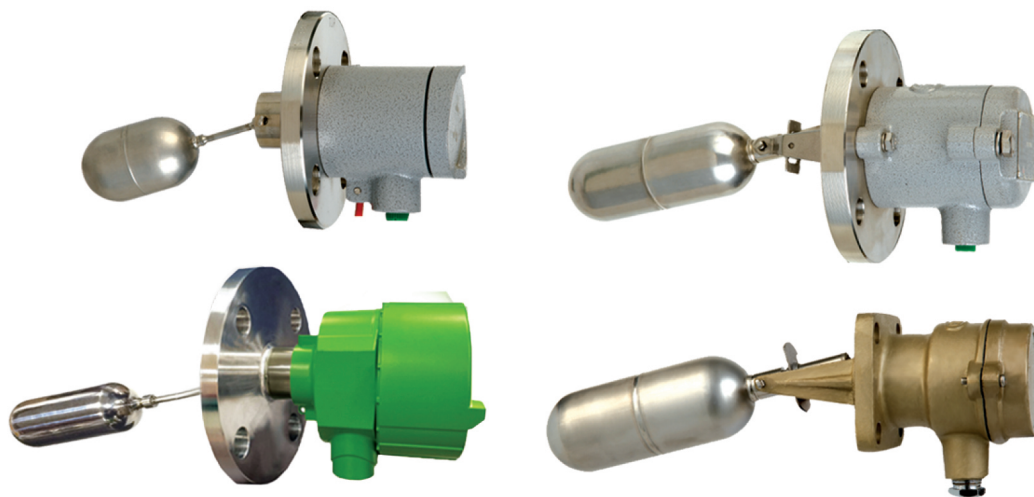

2 YEARS WARRANTY



ASME



www.hitrol.com



Always The Best Solution

HITROL CO., LTD.

Overview

HM-12 Series is a Float Type Level Switch installing on the side of a tank and it is used for the process performing alarm function when filling and discharging of a tank with ON / OFF contact signal. It has an advantage of strong structure and long life cycle, and Weather Proof and Ex-Proof version are available.

Characteristics

- Widely used to detect various liquid levels
- Strong structure and long life cycle
- Applicable to high temperature
- Applicable to corrosive and acidic liquids with anti-corrosive material for the sensor (Teflon)
- Applicable to explosion area (Ex-Proof version)
- No leakage problem due to completely separated float and switch
- Strong durability of the float

Operation Principle

HM-12 is a level switch which uses a force of repulsion by magnetics each other. As the process level rises, the float rises and the float magnet pivots down then the switch magnet is repelled up and it activates the micro switch. It can be used for high or low alarm.

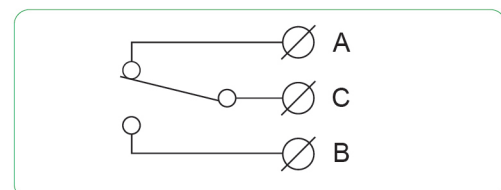
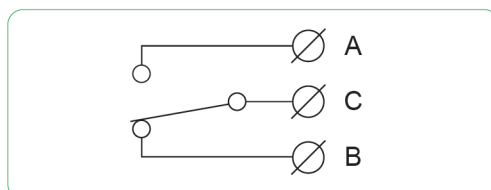
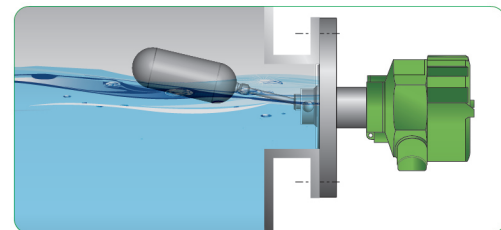
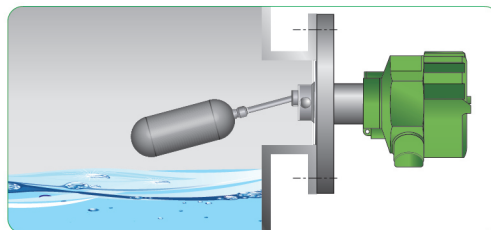
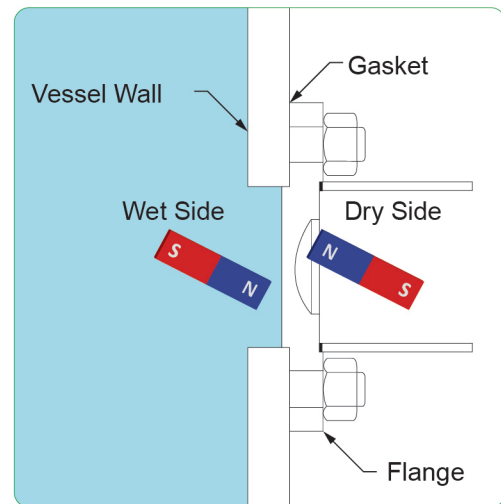
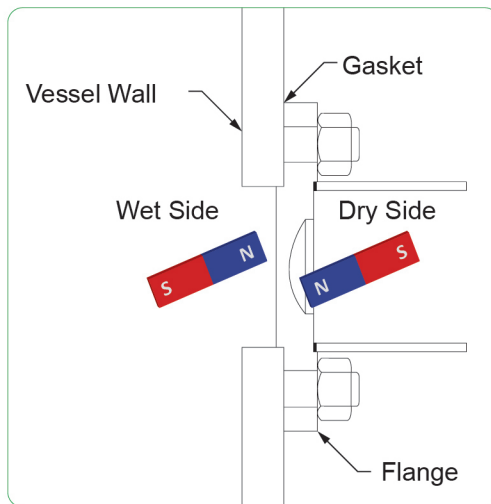

FLOAT TYPE LEVEL SWITCH
HM-12(10) series

Specification

Model	HM-12S	HM-12H	HM-12H-Ex	HM-12D
Mounting	Flange			Square Flange
Ambient Temperature	-20°C ~ +60°C		-20°C ~ +80°C	-20°C ~ +60°C
Process Temperature	Max. 120°C		T6 (Max. 120°C) T5 (Max. 80°C) T4 (Max. 70°C)	Max. 120°C
Process Pressure	Up to 10kg/cm ² (150#)	Up to 20kg/cm ² (300#)		Up to 10kg/cm ² (150#)
Output Signal	1-DPDT		1-SPDT / DPDT	1-SPDT
Contact Rating	AC 250V, 10A DC 30V, 5A		AC250V, 15A DC125V, 0.5A	AC250V, 10A DC125V, 0.5A
Enclosure	Weather Proof (IP66)	Weather Proof (IP65)	Ex-Proof (Ex d IIC T4/T5/T6)	Weather Proof (IP65)
Wetted Part Material	SUS 316L			SUS 316L + B.S
Process Connection	40A JIS 10K RF (std.)	65A JIS 10K RF (std.)		Squares (92x92mm)
Housing Material	Aluminum		Aluminum + SUS 304	B.S
Cable Entry	PF 1/2"(F)			

HM-12(10) Series

Model	HM-12H-SP	HM-12H-SP-Ex	HM-12H-L	HM-12H-L-Ex
Mounting	Flange			
Ambient Temperature	-20°C ~ +60°C			-20°C ~ +80°C
Process Temperature	Max. 250°C	T3 (Max. 150°C) T2 (Max. 250°C)	Max. 120°C	T6 (Max. 120°C) T5 (Max. 80°C) T4 (Max. 70°C)
Process Pressure	Up to 20kg/cm ² (300#)			
Output Signal	1-SPDT		1-DPDT	
Contact Rating	AC 125V, 5A AC 250V, 3A		AC 250V, 10A DC 30V, 5A	AC250V, 15A DC125V, 0.5A
Enclosure	Weather Proof (IP66)	Ex-Proof (Ex d IIC T2/T3)	Weather Proof (IP65)	Ex-Proof (Ex d IIC T4/T5/T6)
Wetted Part Material	SUS 316L			
Process Connection	65A JIS 10K RF (std.)		80A JIS 10K RF (std.)	
Housing Material	Aluminum + SUS 304		Aluminum	Aluminum + SUS 304
Cable Entry	PF 1/2"(F)			

► **Order Code** can be printed at our website (www.hitrol.com)

Dimension

HM-12H

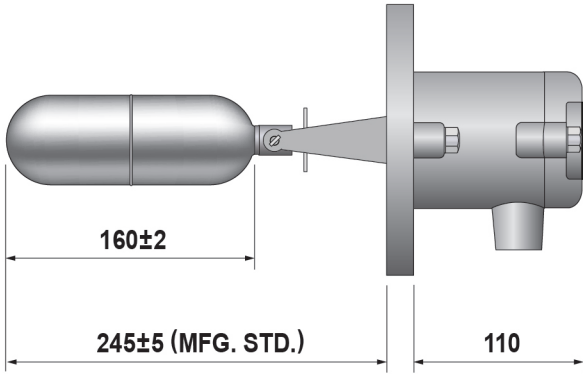

HM-12H-Ex

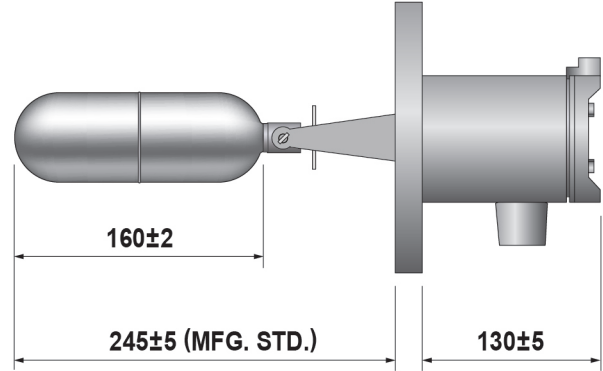

HM-12S

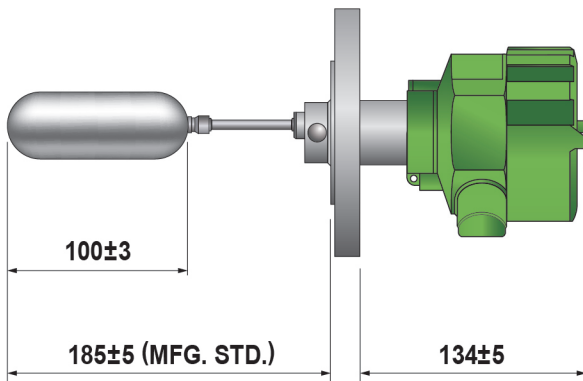

HM-12D

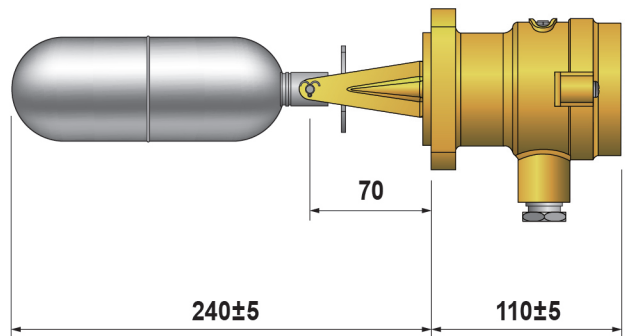

HM-12H-L

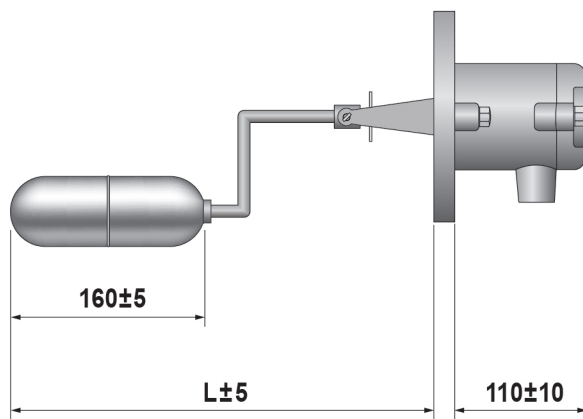

HM-12H-L-

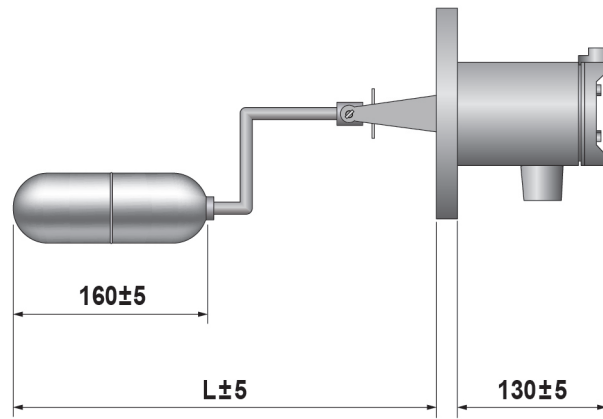

■ Actual product may have a tolerance slightly.

HM-12H-SP

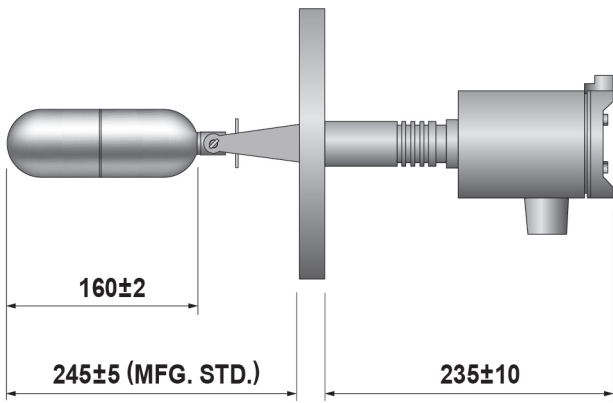

HM-12H-SP-Ex

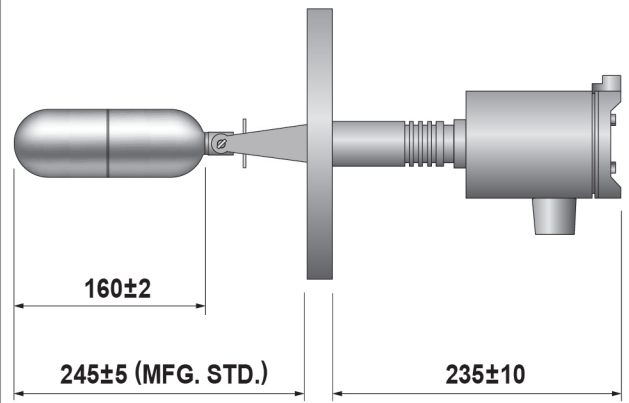

External Chamber

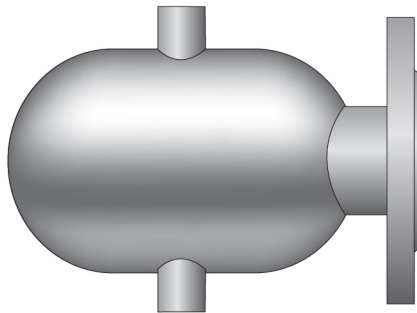

■ Actual product may have a tolerance slightly.

Application

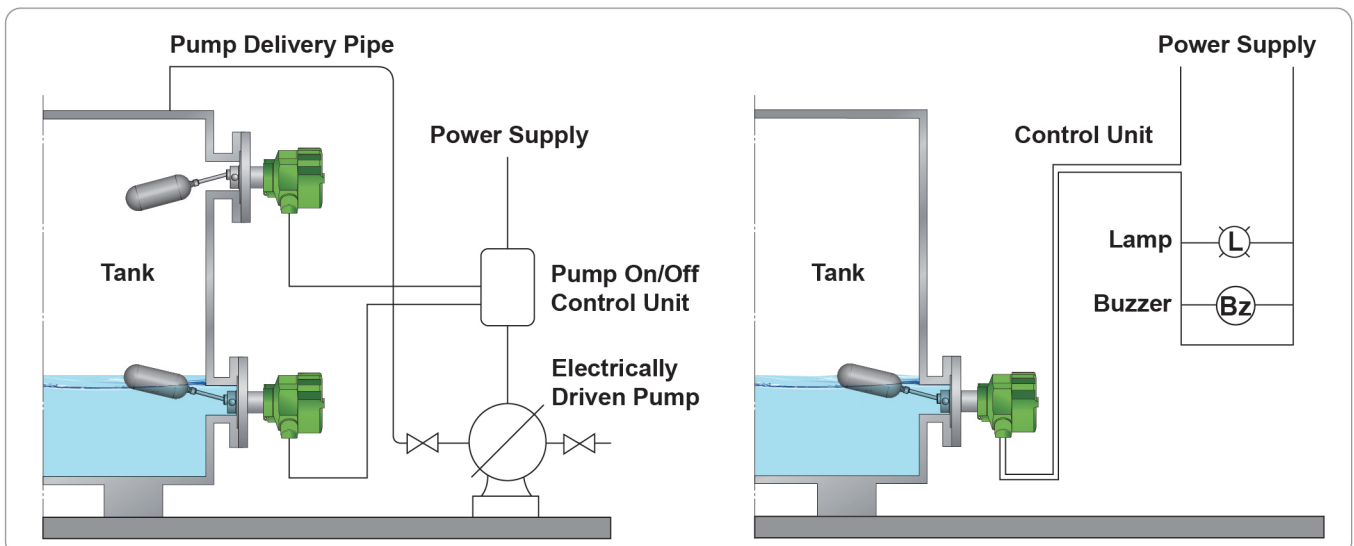



FLOAT TYPE LEVEL SWITCH

HM-12 Series

- 01 Various applications
- 02 Strong structure and high durability
- 03 Easy and convenient installation



 hitrol@hitrol.com

 www.hitrol.com

* Design of product can be changed for upgrade without notice.